

» WK02+ 230V

Condensation detector with temperature and humidity

thermokon[®]
HOME OF SENSOR TECHNOLOGY

Datasheet

Subject to technical alteration
Issue date: 14.08.2020 • A110

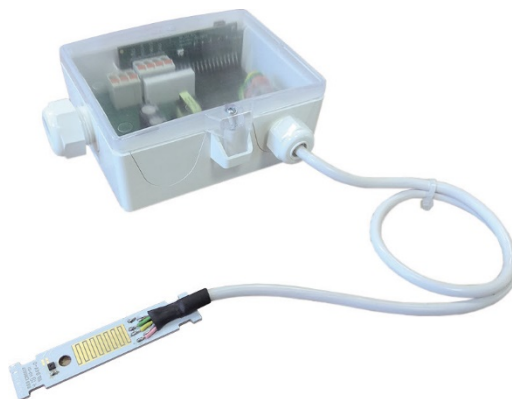

» APPLICATION

Condensation sensor with LED signal designed to provide a switched output signal to prevent condensation on chilled surfaces such as chilled beams. With signal LED and relay contact, there are also 2 analog 0..10 V outputs available with which dew point and temperature are output in the delivery state for control and monitoring applications or for series connection with the cooling valve in order to interrupt the cooling water flow directly at the beginning of condensation.

» TYPES AVAILABLE

Condensation sensor + humidity + temperature – 2x 0..10 V | optional with display

WK02+ ext. 230 V

» SECURITY ADVICE – CAUTION



The installation and assembly of electrical equipment should only be performed by authorized personnel.

The product should only be used for the intended application. Unauthorised modifications are prohibited! The product must not be used in relation with any equipment that in case of a failure may threaten, directly or indirectly, human health or life or result in danger to human beings, animals or assets. Ensure all power is disconnected before installing. Do not connect to live/operating equipment.



CAUTION! Risk of electric shock due to live components within the enclosure, especially devices with mains voltage supply (usually between 90..265 V).

Please comply with

- Local laws, health & safety regulations, technical standards and regulations
- Condition of the device at the time of installation, to ensure safe installation
- This data sheet and installation manual

» PRODUCT TESTING AND CERTIFICATION



Declaration of conformity

The declaration of conformity of the products can be found on our website <https://www.thermokon.de/>.

» NOTES ON DISPOSAL



As a component of a large-scale fixed installation, Thermokon products are intended to be used permanently as part of a building or a structure at a pre-defined and dedicated location, hence the Waste Electrical and Electronic Act (WEEE) is not applicable. However, most of the products may contain valuable materials that should be recycled and not disposed of as domestic waste. Please note the relevant regulations for local disposal.

» TECHNICAL DATA

Measuring values	Humidity, temperature, conductivity			
Output voltage	2x 0..10 V or 0..5 V (adjustable via USEapp; live-zero configuration via Thermokon USEapp)			
Output switch contact	changeover contact, max. 250 V ~ / 3,0 A (resistive, floating)			
Power supply	230 V ~ (±10%)			
Power consumption	typ. 3,5 VA			
Output signal range temp (Scaling analog output)	0..+50 °C (default setting), selectable from 4 temperature ranges -40..+60 0..+50 -20..+80 -15..+35 °C, optionally configurable via Thermokon USEapp			
Measuring range humidity (configurable)	rel. humidity 0..100% rH non-condensing	abs. humidity 0..50 0..80 g/m ³	enthalpy 0..85 KJ/kg	dew point 0..50 -20..+80 °C 0..+50 °C (default)
Accuracy temperature	±0,5 K (typ. bei 21 °C im Standardmessbereich)			
Accuracy humidity	±2% between 10..90% rH (typ. at 21 °C)			
Display	LED green – power supply OK, LED red – condensation		Optional: LCD 29x35 mm with RGB backlight	
Enclosure	enclosure USE-L, PC, pure white, cover PC, transparent, with removable cable entry			
Protection	IP65 according to EN 60529			
Cable entry	Flextherm M20 for wire Ø=4.5..9 mm, M25, for wire max. Ø=7 mm, seal insert for fourfold cable entry			
Connection electrical	removable plug-in terminal, max. 2,5 mm ² , sensor wire white 2 m (default), for other lengths please request			
Ambient condition	0..+50 °C, max. 85% rH short term condensation			
Delivery content	1x syringe with terminal contact fluid, incl. mounting base enclosure USE-L pure white			

» USE ENCLOSURE WITH UV AND WEATHER RESISTANCE

After some time, outdoor mounted plastics can lose their color and quality. Therefore, all USE housings are made of special white polycarbonate (PC). The light-stable colorants and additives are used to achieve optimum protection of the polymer while maintaining color stability. The titanium dioxide used is specially developed for polycarbonate and offers excellent UV protection through the reflection of the entire light spectrum including the UV component by 340 nm. This effectively counteracts the otherwise occurring photochemical polymer degradation. The colors stay full for a long time without fading. The material is also resistant to cold and frost.

» MOUNTING ADVICE

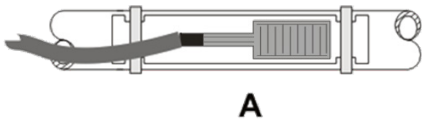

A

For detection of water condensation, the sensor must be mounted on the coldest point of the medium. Please ensure a good thermal contact to the measuring medium. A thermal connection between sensor and medium with heat conducting paste is necessary. Mounting effects by means of included cable ties (binders). Mounting can be made directly on a pipeline.

The sensor surface may be damaged by an aggressive and solvent-contaminated ambient. Always keep the sensor clean and free of dust and dirt. A dirt film may affect the sensor's switching characteristic.

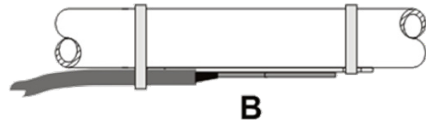

B

Note the mounting side of the metal strip (see the figure A).

In order to avoid dust deposits, the sensor should be installed at the bottom of the pipe if possible (see the figure B).

» CONFIGURATION



The Thermokon bluetooth dongle with micro-USB is required for communication between USEapp and USE-M / USE L (Item No.: 668262). Commercial bluetooth dongles are not compatible.



Application-specific reconfiguration of the devices can be carried out using the Thermokon USEapp. The configuration is carried out in the voltage-supplied state.



The configuration-app and the app description can be found in the Google Play Store or in the Apple App Store.

» APPLICATION NOTICE



The Bluetooth dongle snaps into the socket easily. When removing, please fix the plug-in card (option PCB) so that it is not unintentionally pulled out.

After a certain time, dirt in the air can collect on the sensor and then adversely affect the operation of the sensor. Under normal ambient condition an annual maintenance is recommended. Rinse the sensor after cleaning with distilled water and dry it using clean oil-free air or nitrogen.

» CONNECTION PLAN

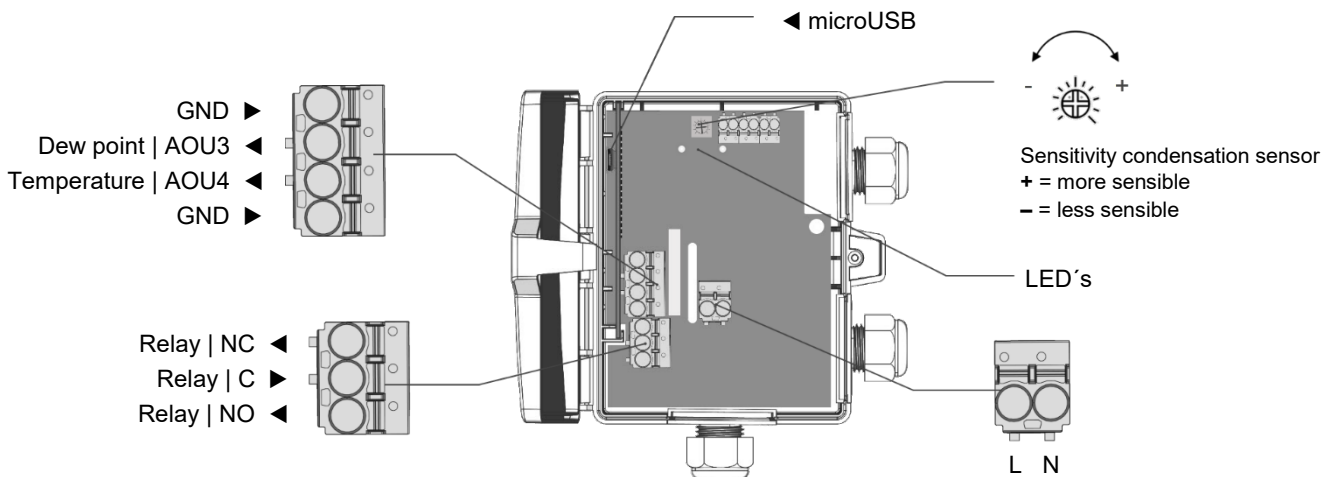

The relay is energized in the operating state (relays NO and C connected). Upon dew permeation or when the operating voltage is switched-off, the relay falls off.

Type with RGB display: to set the sensitivity of the condensation sensor, the display must be removed from the board first.

» DISPLAY

Parameters, such as the fading in / out of measured values, brightness and TLF function, are changed via the app. During the boot process, the software and hardware versions are displayed. The RGB display visually displays measured values. Thresholds for color changes can be configured through the app.

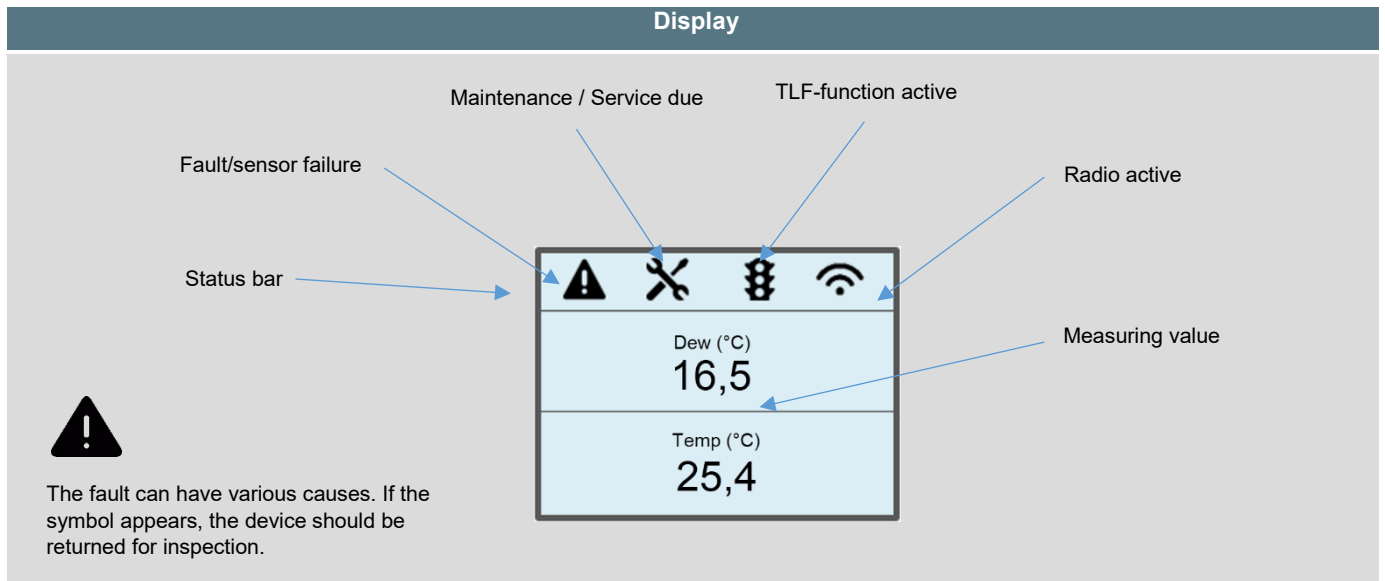

» DIMENSIONS (MM)

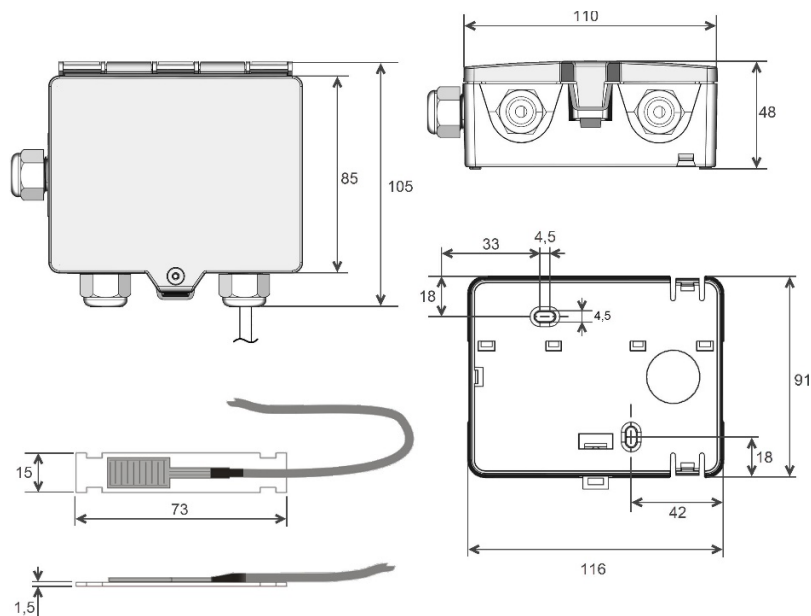

» ACCESSORIES (INCLUDED IN DELIVERY)

- Syringe with terminal contact fluid
- Cable ties 140x3,6 mm
- Mounting kit universal
- Cover screw + screw cover • 2 Rawlplugs • 2 Screws (countersunk head) • 2 Screws (rounded head)

Item No. 102308
Item No. 007610
Item No. 698511

» ACCESSORIES (OPTIONAL)

- Cable entry M25 USE white, sealing insert 4x Ø=7 mm (4 pcs)
- Sealing insert M20 USE white, 2x Ø=7 mm (for 2 wire; PU 10 pieces)

Item No. 641364
Item No. 641333